



BLUELINE[®]
Vacuum Technologies, Inc.

FICHA TÉCNICA

TITANIUM[®] L 200

Bomba de Vacío de Una Etapa

Conexión de Entrada	G 2"
Conexión de Salida	G 2"
Velocidad de Bombeo a 60 Hz	240 m ³ / hr
Presión Final sin Gas Ballast	0.08 mbar
Presión Parcial Final con Gas Ballast	0.5 mbar
Tolerancia al Vapor de Agua a 60 Hz	60 mbar
Capacidad de Vapor de Agua a 60 Hz	600 gramos /hr
Fluido Operativo	UG40S Oil
Capacidad de Aceite de Operación en	7 L
Nivel de ruido	70 Db
Clasificación del motor	4kw/5hp - 220V - 440V/3ph/60 hz
Velocidad de Rotación a 60 hz	1720
Temperatura Ambiente Admisible	10 a 40 Celsius
Peso	132 kg
No. de filtros de salida	2
Enfriamiento	Aire

- Robusta y confiable



Titanium L 200

Incluye
Gas Ballast



- Calidad suprema
de manufactura



CAPACIDAD DE BOMBEO Y

DIMENSIONES

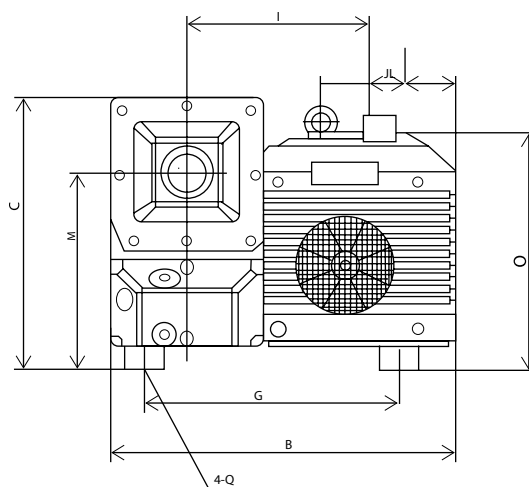
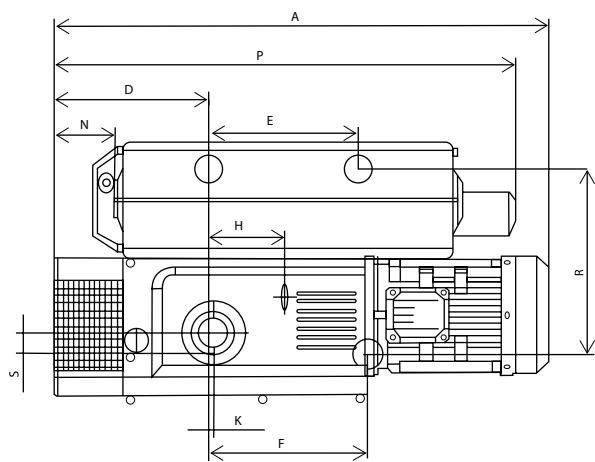
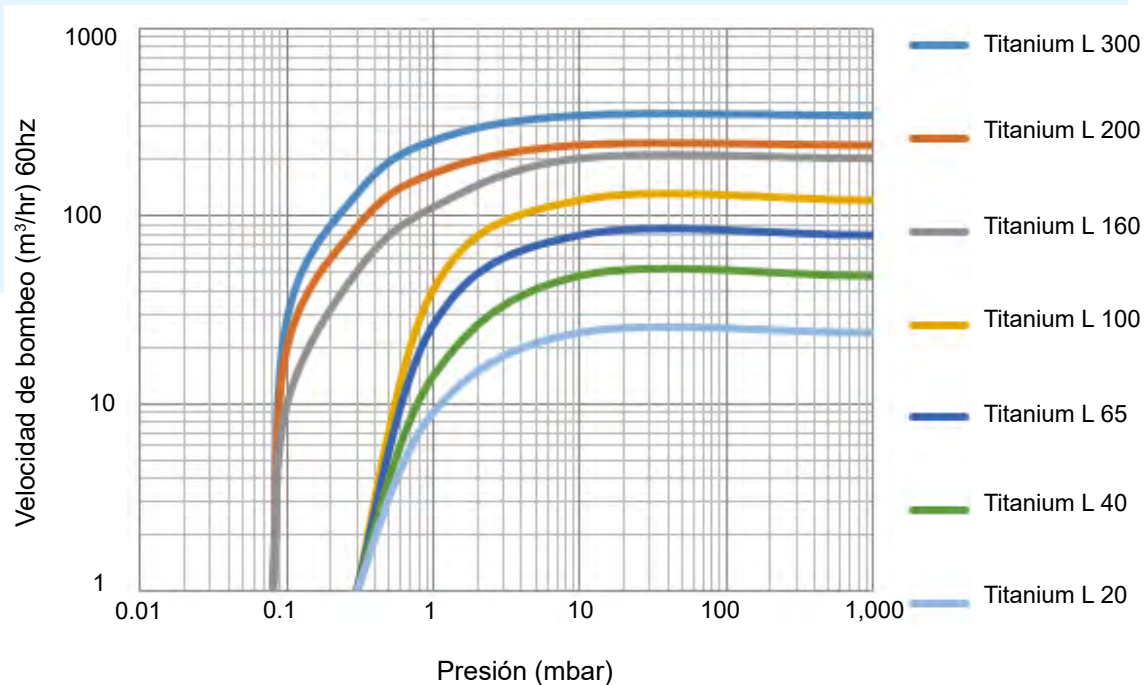

MODELO	A	B	C	D	E	F	G	H	I	J	K	ENTRADA	SALIDA
TitaniumL 200	930	533	436	263	252	305	394	113	298	66	32	G2"	G2"

MODELO	L	M	N	O	P	Q	R	S	ENTRADA	SALIDA
TitaniumL 200	135	305	134	382	930	M10	394	45	G2"	G2"

