



BLUELINE[®]
Vacuum Technologies, Inc.

FICHA TÉCNICA

TITANIUM[®] L 40

Bomba de Vacío de Una Etapa

Conexión de Entrada	G 1-1/4"
Conexión de Salida	G 1-1/4"
Velocidad de Bombeo a 60 Hz	48 m ³ / hr
Presión Final sin Gas Ballast	0.08 mbar
Presión Parcial Final con Gas Ballast	0.5 mbar
Tolerancia al Vapor de Agua a 60 Hz	30 mbar
Capacidad de Vapor de Agua a 60 Hz	600 gramos /hr
Fluido Operativo	UG40S Oil
Capacidad de Aceite de Operación en	2 L
Nivel de ruido	65 Db
Clasificación del motor	1.1kw/1.5hp - 220V - 440V/3ph/60 hz
Velocidad de Rotación a 60 hz	1720
Temperatura Ambiente Admisible	12 a 40 Celsius
Peso	45 kg
No. de filtros de salida	1
Enfriamiento	Aire

- Robusta y confiable



Titanium L 40

Incluye
Gas Ballast

- Calidad suprema
de manufactura



CAPACIDAD DE BOMBEO Y

DIMENSIONES

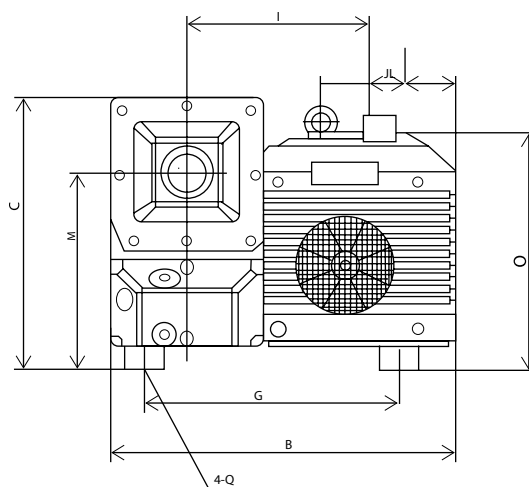
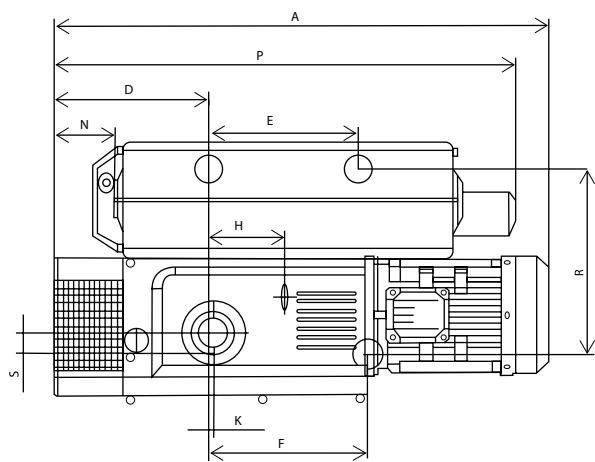
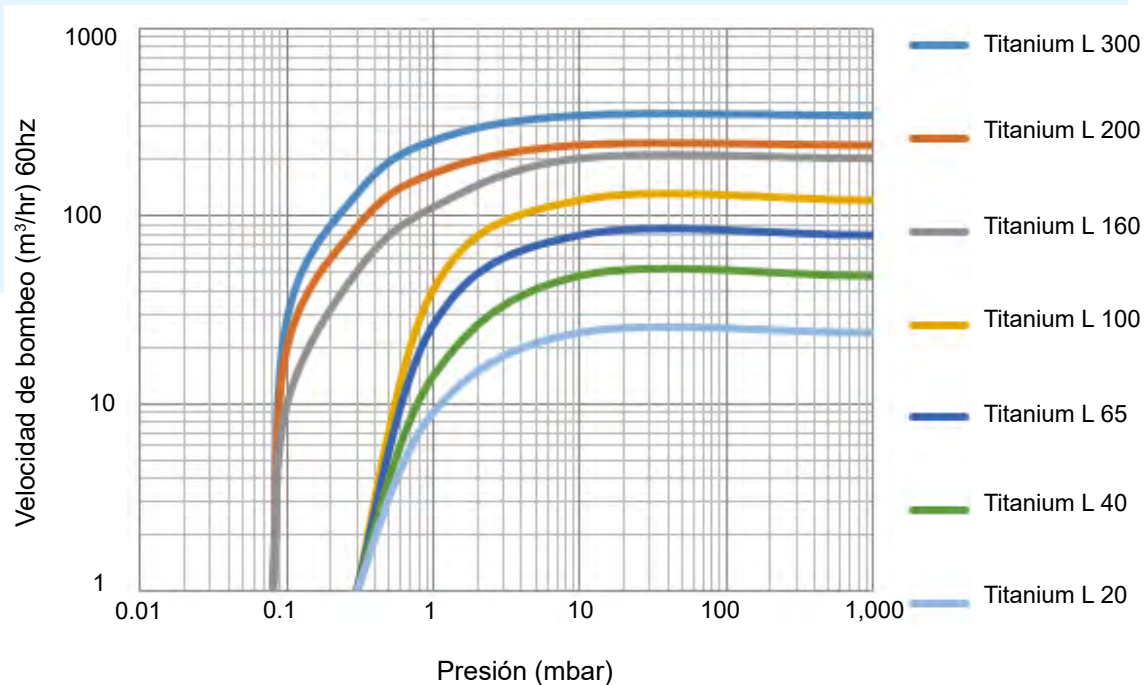

MODELO	A	B	C	D	E	F	G	H	I	J	K	ENTRADA	SALIDA
TitaniumL 40	555	304	268	149	215	200	235	58	179	51	5	1-1/4"	1-1/4"

MODELO	L	M	N	O	P	Q	R	S	ENTRADA	SALIDA
TitaniumL 40	72	203	33	252	464	M10	235	33	1-1/4"	1-1/4"

COMPONENTES

