



BLUELINE®

Vacuum Technologies, Inc.

"Keep evolving..."

SERIES TITANIUM® L

Bombas de Paletas Rotativas con Sello de Aceite



IDEAL PARA LAS SIGUIENTES

APLICACIONES



Gas Ballast



Válvula Anti Retorno

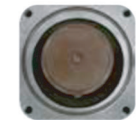

De fácil mantenimiento



MODELO	TITANIUM L 20	TITANIUM L 40	TITANIUM L 65	TITANIUM L 100	TITANIUM L 160	TITANIUM L 200	TITANIUM L 300
Desplazamiento m ³ /h (60 Hz)	24	48	75	120	192	300	360
Presión final (Torr)	0.08	0.08	0.08	0.08	0.08	0.08	0.08
Potencia (kW) a 60 Hz	0.75	1.1	1.5	2.2	4	7.5	7.5
Conexión (Salida/Entrada) ASME	G 3/4 "	G 1-1/4 "	G 1-1/4 "	G 1-1/4 "	G 2"	G 2"	G 2"
Flujo de agua de refrigeración (l/min)	0.5	2	7	7	9	9	9
Velocidad del motor (RPM)	3600	1720	1720	1720	1720	1720	1720
Nivel de ruido (dB)	≤ 64	≤ 67	≤ 68	≤ 72	≤ 74	≤ 76	≤ 77
Peso (KG)	20	45	50	72	132	132	205
Número de Catálogo	BLT0020T	BLT0040T	BLT0065T	BLT00100T	BLT00160T	BLT00200T	BLT00300T

Bombas de Paletas Rotativas de Una Etapa con Sello de Aceite

Operación Silenciosa

Presión Final de 8×10^{-2} Mbar

Velocidades de 24 a 360 m³xhr

ALTAMENTE CONFIABLE

CAPACIDAD DE BOMBEO Y

DIMENSIONES

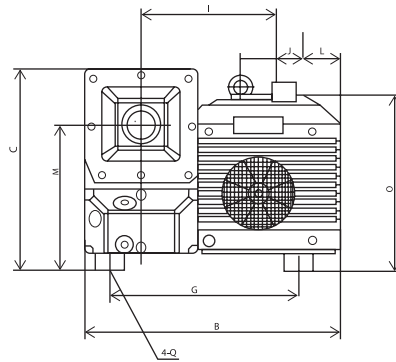
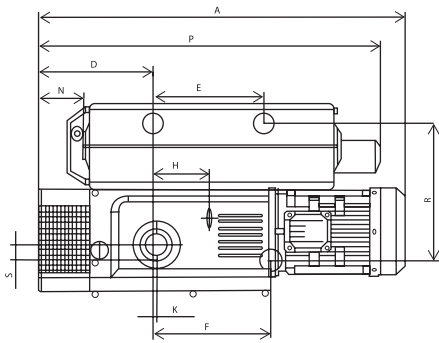
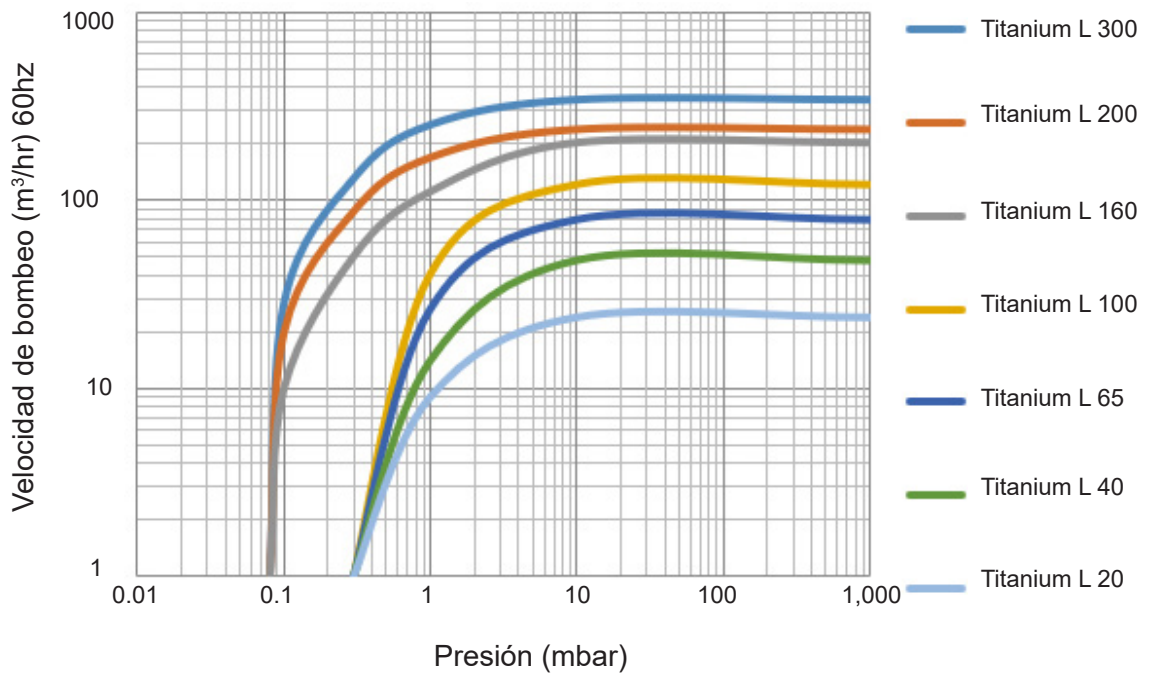

MODELO NO.	A	B	C	D	E	F	G	H	I	J	ENTRADA	SALIDA
Titanium L 20	317	249	219	72	140	110	131	128			G3/4"	G3/4"
Titanium L 40	555	304	268	149	215	200	235	58	179	51	G1"1/4"	G1"1/4"
Titanium L 65	555	311	268	149	215	200	235	58	189	51	G1"1/4"	G1"1/4"
Titanium L 100	703	406	286	165	225	225	320	131	225	42	G1"1/4"	G1"1/4"
Titanium L 160	930	533	434	263	252	305	394	113	295	66	G2"	G2"
Titanium L 200	930	533	434	263	252	305	394	113	295	66	G2"	G2"
Titanium L 300	1035	540	434	326	313	313	394	159	284	75	G2"	G2"

MODELO NO.	K	L	M	N	O	P	Q	R	S	ENTRADA	SALIDA
Titanium L 20	14	72	157	17	184	303	M8	125	5.3	G3/4"	G3/4"
Titanium L 40	5	72	203	33	252	464	M10	235	33	G1"1/4"	G1"1/4"
Titanium L 65	5	72	203	33	252	464	M10	242	33	G1"1/4"	G1"1/4"
Titanium L 100	27	91	220	61	280	578	M10	258	41	G1"1/4"	G1"1/4"
Titanium L 160	32	135	305	134	382	930	M10	394	45	G2"	G2"
Titanium L 200	32	135	305	134	382	930	M10	394	45	G2"	G2"
Titanium L 300	11	135	314	132	377	966	M10	394	45	G2"	G2"

(milímetros)